

Garrard

Service information for Model MRM101 Music Recovery Module

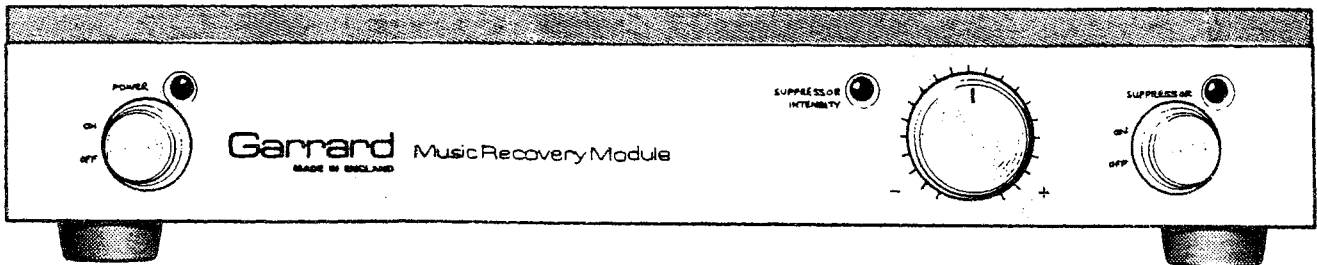

Index

	<i>page</i>
Introduction	2
Connections	2
Operation	3
Spare parts list	4
Circuit diagram	7
Dismantling	12
Test procedures	12

Details of authorised Garrard service centres are available on request.

Garrard Sales Service Department,
Crowdy's Hill Estate, Kembrey Street,
Swindon, SN2 6BP, Wiltshire, England.
Telephone: Swindon (0793) 41701.
Telex: 44271.

In U.S.A.:
Plessey Consumer Products,
Garrard Dealer Sales Division,
100 Commercial Street,
Plainview, New York 11803.
Telephone: (516) 938 8900.

Model MRM101 Music Recovery Module

Introduction

The Music Recovery Module (referred to as MRM) is designed to remove the objectionable noises heard when a phono pickup meets a scratch on the record being played.

The MRM is not intended to remove all noises associated with old, worn or generally dirty records. Since these noises occur in an almost continuous manner, their detection could lead to the removal of a substantial proportion of the original recording.

The MRM contains a high quality stereo pre-amplifier with magnetic phono inputs. This allows the MRM to be simply and directly connected to the amplifier 'auxiliary' or 'tuner' inputs. The scratch detection circuit recognises the whole waveform of

the scratch and distinguishes it from the peaks of the recorded music. In order to allow the scratch detection circuit sufficient time to make the decision to remove the scratch, the channels are individually delayed by a few milli-seconds without limiting the audio frequency range.

After recognising the scratch, a specially designed network isolates the signal for sufficient time for the scratch noise to pass out of the delay line.

Patents applied for.

WARNING: To prevent fire or shock hazard, do not expose this appliance to rain or moisture.

Specifications

Input

Suitable for pickup cartridges having an output of 0.7 to 2mV/cm/sec.

Input impedance

47k ohm.

Frequency response

± 1.5dB 20Hz to 20kHz (including equalisation network for magnetic cartridges).

Dynamic range

Direct mode: greater than 100dB.

Via suppressor: greater than 80dB (typically 85dB).

(Unweighted 20Hz to 20kHz ref. to 1kHz maximum output.)

Distortion

At 1kHz at nominal output:

Direct mode: Typically less than 0.01% T.H.D.

Via suppressor: Typically less than 0.1% T.H.D.

Channel balance

Better than 2dB at 1kHz.

Nominal output

300mV RMS.

Output

For 1% T.H.D. at 1kHz:

Suppressor 'in' 2.5V rms.

Suppressor 'out' 8V rms.

Output impedance

3.3k ohm.

Rated load impedance

Greater than 10k ohm (short circuit protected).

Power supply

120V AC, 50/60Hz 7VA, or 220/240V, AC 50/60Hz 7VA.

Dimensions

378mm × 298mm × 71mm (W × D × H).

Shipping weight

3.7kg (8.16lb).

Garrard's policy is one of continued development and therefore the Company reserves the right to alter specifications without notice.

For Service and Enquiries:

Garrard Engineering Limited,

Sales Service Department,

Kembrey Street,

Swindon, Wiltshire SN2 6BP.

Telephone: Swindon (0793) 41701

Or, in U.S.A.:

Plessey Consumer Products,

Garrard Dealer Sales Division,

100 Commercial Street,

Plainview, New York 11803.

Telephone: (516) 938-8900

Connections

Connecting to the power supply

The power supply lead enters at the right hand side of the rear panel.

Important: Before connecting to the power supply ensure by the voltage instruction label on the back panel that the MRM is suitable for the supply voltage.

1. **United Kingdom only.** A power supply plug is not fitted and as the colours of the wires in the mains lead of the MRM may not correspond to the colours identifying the terminals in your power supply plug proceed as follows:
The BROWN wire must be connected to the terminal in the plug marked 'L' or coloured red.

The BLUE wire must be connected to the terminal in the plug marked 'N' or coloured black.

A separate earth wire is not required.

If a 13 amp (BS1363) plug is used, fit a 3 amp or 5 amp fuse.

For any other type of plug protect with a 5 amp fuse or fuse wire in the adaptor or distributor board.

2. **Europe and U.S.A.** A suitable 2 pin plug is provided for connection to the power supply.

Connections at the rear panel

Connections at the rear panel of the MRM are both RCA and DIN type input and RCA type output sockets to provide the facility to link up to any equipment likely to be used with it.

European versions also have a DIN type output socket.

The RCA connectors are identified L (left) and R (right), so that a signal into the R connector appears after processing on the R output connector.

For convenience, the pickup input and the amplifier output connections are placed at either side of the signal earth (⊕) terminal respectively.

It may be found advantageous to connect a lead between the amplifier or record player and the MRM signal earth terminals, to minimise hum.

Audio connecting leads (U.K. and Europe)

The MRM is supplied with an audio connecting lead specially wired with a 5-pin DIN type plug at one end and RCA type

phono plugs at the other. (Part No. 606/7/79486/001.)

MRM Input: Transfer the amplifier end of the signal lead between the record player and the amplifier to the MRM, using, as appropriate, the DIN input socket or the RCA phono input sockets, observing the R and L channel identification markings.

MRM Output: Connection to the amplifier from the MRM will be to the following colour coding:

Black or Brown plug (RCA) – Socket R (right)

White or Grey plug (RCA) – Socket L (left)

If the amplifier has a 5-way DIN input socket:

1. Attach the 5 pin DIN type plug on the Garrard audio connection lead to this.
2. Attach the RCA type phono plugs on the other end of the lead to the appropriate output sockets on the MRM, observing the R and L channel identification markings.

If the amplifier has RCA type phono input sockets:

1. Attach the phono plugs on the Garrard audio connection

lead to these, observing the R and L channel identification markings.

2. Attach the 5 pin DIN type plug on the other end of the lead to the MRM DIN output socket.

Audio connecting leads (U.S.A.)

The MRM is supplied with a phono connecting lead which has RCA type plugs at each end. (Part No. 606/7/79488/001.)

Connection to the amplifier from the MRM will be to the following colour coding:

Black or Brown plug (RCA) – Socket R (right)

White or Grey plug (RCA) – Socket L (left)

If the amplifier has DIN type sockets attach a 5-pin DIN plug.

The other ends of either type of leads are connected to the MRM as previously stated, and as shown in the following diagram.

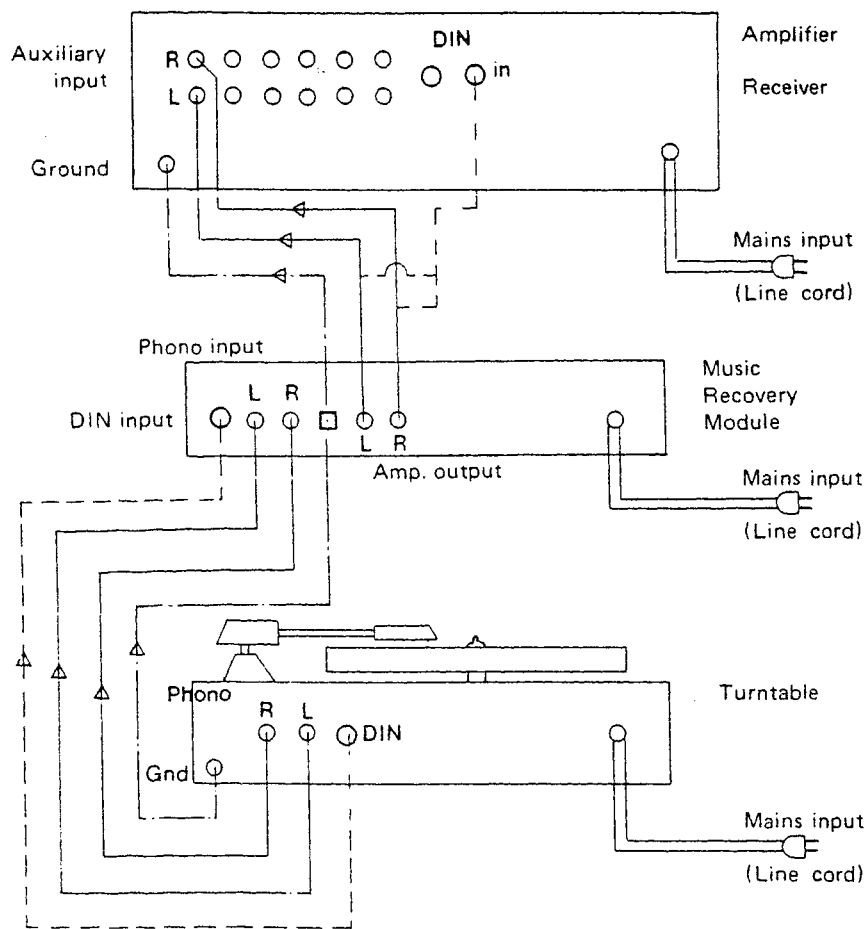

Diagram 1 Connecting leads

Operation

Operating controls

The power supply On/Off switch is at the left side of the fascia panel with an adjacent red indicator light. To avoid switch-on clicks it is advised either that the MRM is switched on before the amplifier or that the amplifier volume controls are at minimum when the MRM is switched on.

At the right-hand side of the front panel is the suppressor switch which activates the scratch suppression circuit, with an associated indicator light to show that the network is in operation when the control is switched in.

The large central control knob provides the adjustment for the sensitivity at which the scratch suppression operates.

Turning the control clockwise causes the unit to be triggered by small scratches (maximum sensitivity). Turning the control

counterclockwise progressively increases the scratch amplitude necessary before triggering occurs.

Triggering of the unit is indicated by the suppressor activity light which flashes when a scratch is detected. The user may therefore choose the level at which suppression occurs in order to obtain the best subjective improvement.

Adjusting the controls

With the connections made as previously stated, and a scratched record playing adjustment is then made. Starting with the sensitivity control turned fully counterclockwise and the suppressor switched out, rotate the sensitivity control clockwise until the suppressor activity light commences flashing in synchronism with the scratch to be suppressed. Switch the suppressor circuit in.

Spare Parts List

(For identification see diagrams 2 - 6)

Ref. No.	Garrard Part No.	Description	Ref. No.	Garrard Part No.	Description
1	702/4/26585/001	'Heyco' strain relief bush - U.K. and Europe	26	999/4/31037/001	'Rokut' rivet (5)
	702/4/26564/001	'Heyco' strain relief bush - U.S.A.	27	419/7/41485/001	Main P.C.B. - U.K. and Europe
2	998/4/70277/006	Mains lead - U.K.		419/7/41485/002	Main P.C.B. - U.S.A.
	702/7/26572/001	Mains lead with Europlug - Europe	28	612/7/41333/001	Fascia panel
	606/4/73278/001	Line cord - U.S.A.	29	612/7/41327/001	Fascia panel spacer (3)
3	612/7/41332/001	Chassis label - U.K. and Europe	30	408/7/51889/001	Power supply switch - SW1
	612/7/41332/002	Chassis label - U.S.A.	31	518/4/90640/007	Fuse 100mAT - FS1
4	612/7/41302/001	Chassis plate	32	612/7/41322/001	Wiring loom, with power supply socket SK5
5	508/4/22429/001	Phono socket (4)	33	612/7/41338/001	Pillar (3)
6	703/4/06094/001	Earthing (grounding) terminal	34	999/4/01911/006	Nut, M5 (6)
7	508/4/22430/001	5 pin DIN socket - U.K. and Europe (2)	35	999/4/00852/019	Shakeproof washer, M5 (3)
	508/4/22430/001	5 pin DIN socket - U.S.A. (1)	36	405/7/17125/005	Power supply transformer - TR1 - U.K. and Europe
8	991/4/02076/097	Screw - U.K. and Europe (4)		405/7/17125/006	Power supply transformer - TR1 - U.S.A.
	991/4/02076/097	Screw - U.S.A. (2)	37	612/7/41337/001	Transformer plate
9	999/4/00852/008	Shakeproof washer - U.K. and Europe (4)	38	999/4/31023/004	Nylon washer, M3 (8)
	999/4/00852/008	Shakeproof washer - U.S.A. (2)	39	612/7/41303/002	Cabinet - 'black sand' finish
10	991/4/01914/004	Nut - U.K. and Europe (4)		612/7/41303/003	Cabinet - 'walnut' finish
	991/4/01914/004	Nut - U.S.A. (2)	40	991/4/02000/037	Crinkle washer (2)
11	612/7/41306/001	Wiring loom, with input socket SK1	41	999/4/31048/001	Screw, M3 (2)
12	612/7/41317/001	Wiring loom, with output socket SK2	42	606/7/80077/001	Isolator foot (4)
13	419/7/41487/002	Sub-P.C.B.	43	606/2/80078/001	Isolator bush (4)
14	612/7/41323/001	Fader assembly, complete	44	999/4/01145/026	Screw (4)
	612/7/41301/001	Fader housing (2)	45	606/7/79486/001	Audio connecting lead (phono/DIN plug) - U.K. and Europe
15	991/4/02018/099	Screw, M3		606/7/79488/001	Audio connecting lead (phono/phono plugs) - U.S.A.
	991/4/01726/005	Nut, M3 (not shown)	Miscellaneous parts (not illustrated)		
16	998/4/83976/001	Light-proof tape, 5 x 260mm		612/7/41313/001	Packing carton
17	612/7/41318/001	Wiring loom, with function control socket SK3		612/7/41334/001	Polystyrene packing piece (2)
	612/7/41321/001	Wiring loom, with sensitivity control socket SK4		612/7/41335/001	Cardboard packing piece (2)
19	404/7/08179/001	Sensitivity control - VR3		612/7/41312/001	Customer's instruction leaflet - U.K. and Europe
20	520/4/95012/001	Lamp mounting bush, with collar (3)		612/7/41312/002	Customer's instruction leaflet - U.S.A.
21	408/7/51890/001	Suppressor switch - SW2			Signal ground connecting lead
22	520/4/95006/001	Indicator lamp, diffused red - LED 1 and 3 (2)			
23	612/7/41320/001	Control knob, small (2)			
24	612/7/41319/001	Control knob, large			
25	520/4/95007/001	Indicator lamp, clear red - LED 2			

Printed Circuit Board Components

Reference numbers are those used on diagrams 10, 11 and 12. Components without a 'Garrard Part Number' are proprietary items and should be obtained locally.

Ref. No.	Garrard Part Number	Description
Resistors ½ watt ± 5% unless otherwise stated		
R101		47K
R102		10K
R103		100K
R104		680R
R105		2K2
R106		360K ½ watt ± 2%
R107		39K ½ watt ± 2%
R108		3K3
R109		3K3
R110		3K3
R111		4K7
R112		2K7
R113		56K
R114		820R
R115		1M
R116		120K
R117		120K
R118		3K3
R119		3K3
R120		1M
R121		39K
R122		51K ½ watt ± 2%
R123		3K3
R124		22R
R125		10K
R126		1K5
R127		47K

Continued on page 9

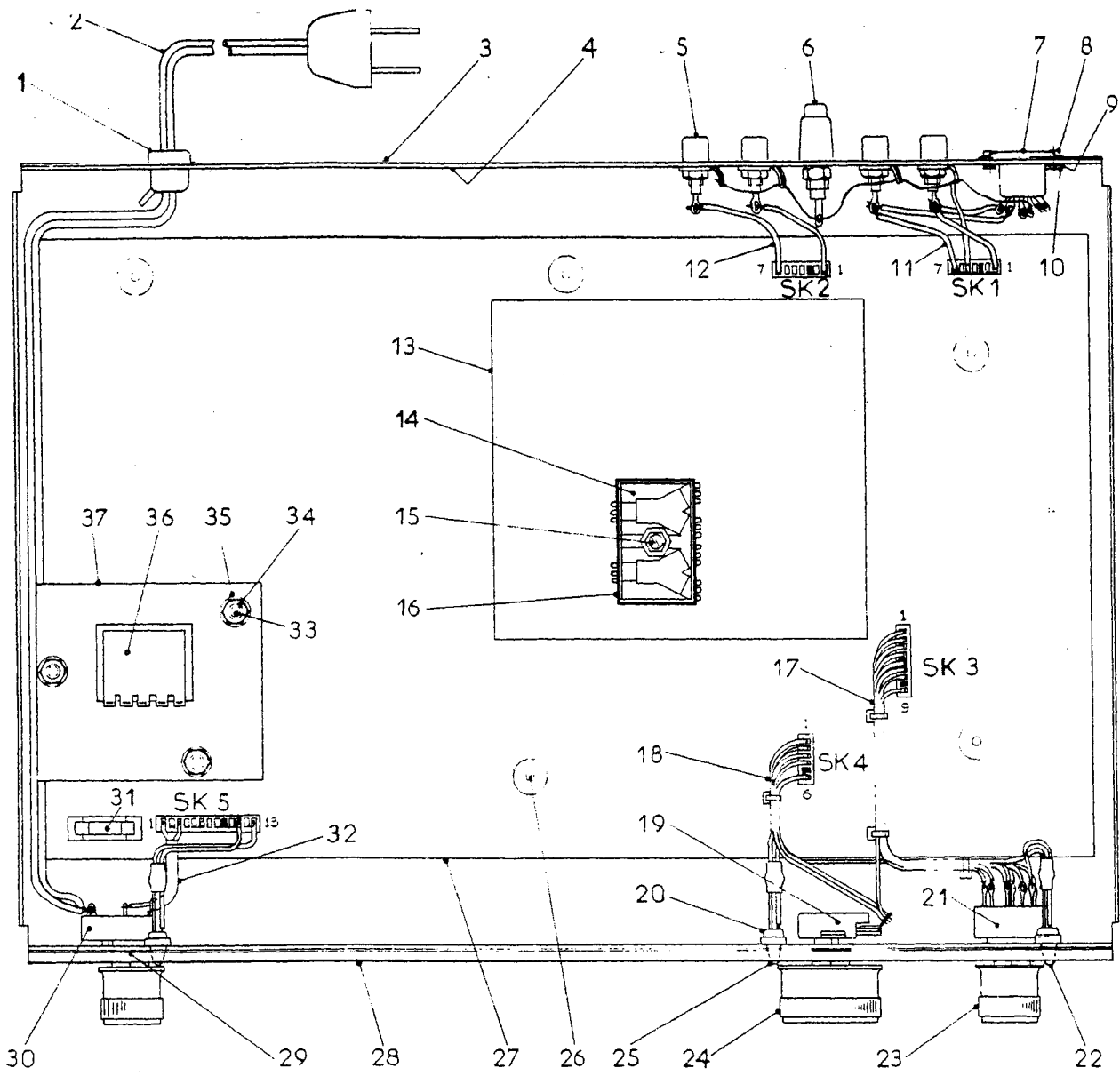

Diagram 2 View from above - cabinet removed

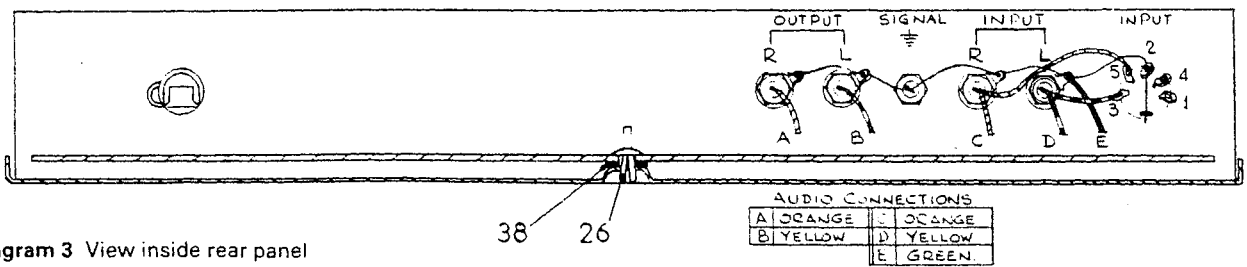

Diagram 3 View inside rear panel

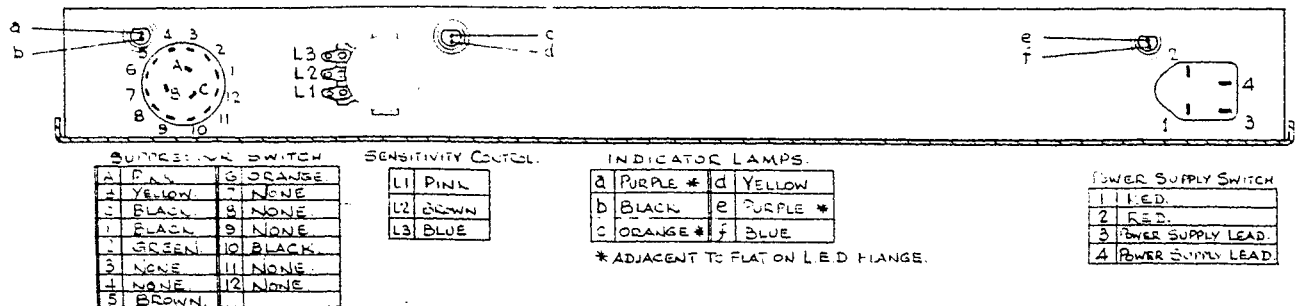

Diagram 4 View inside front panel

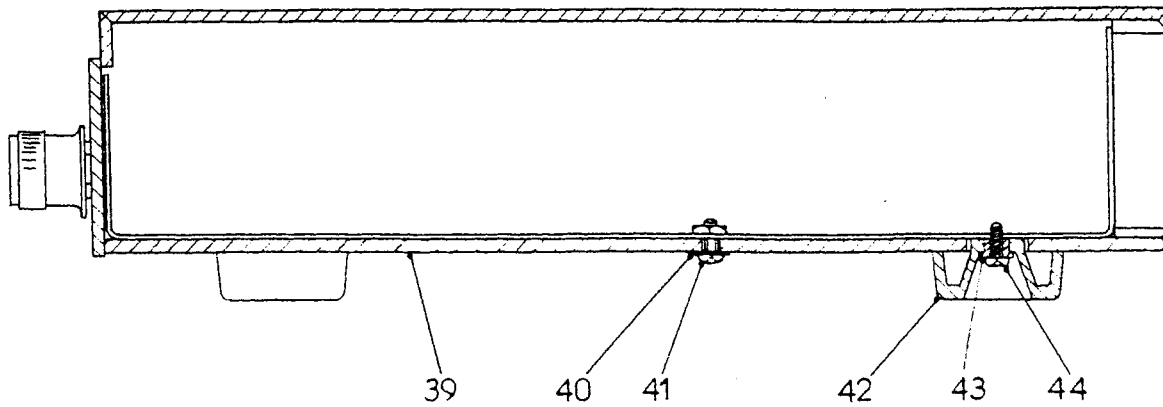

Diagram 5 Cabinet fixing

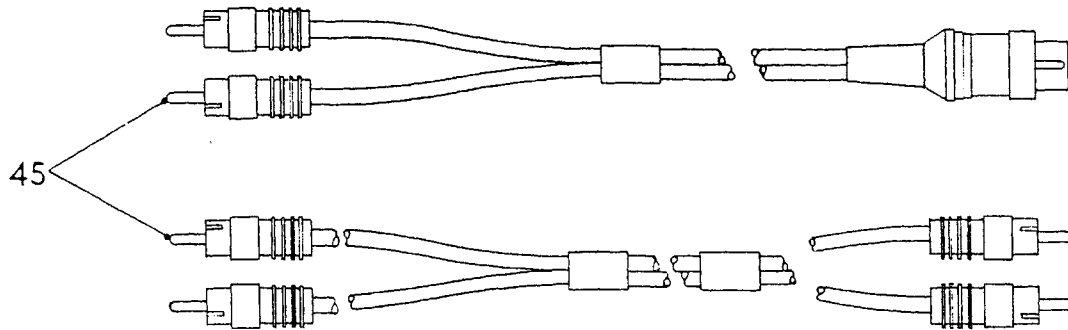

Diagram 6 Audio connecting leads

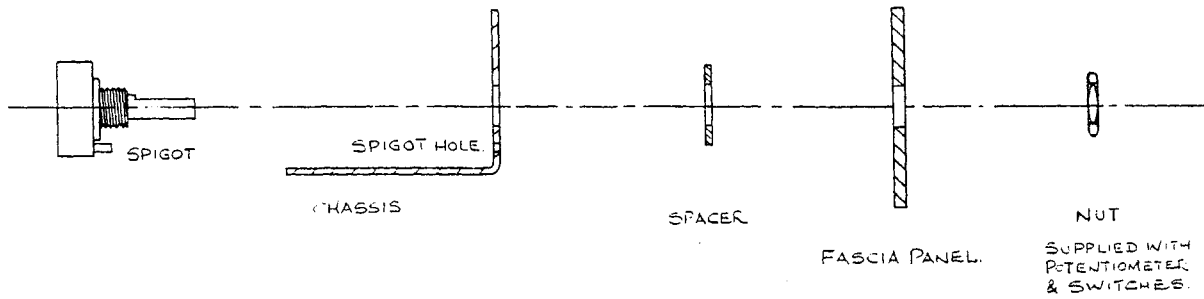

Diagram 7 Potentiometer and switch fixing

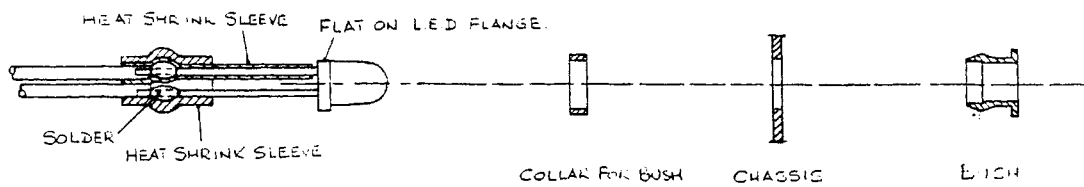

Diagram 8 Indicator lamp fixing

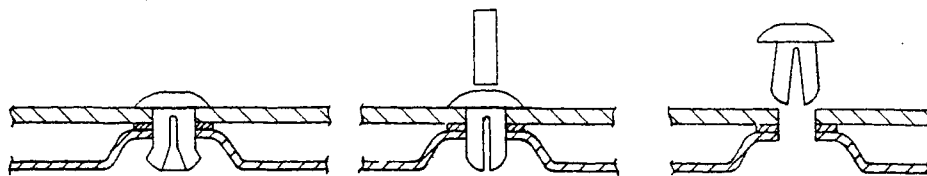
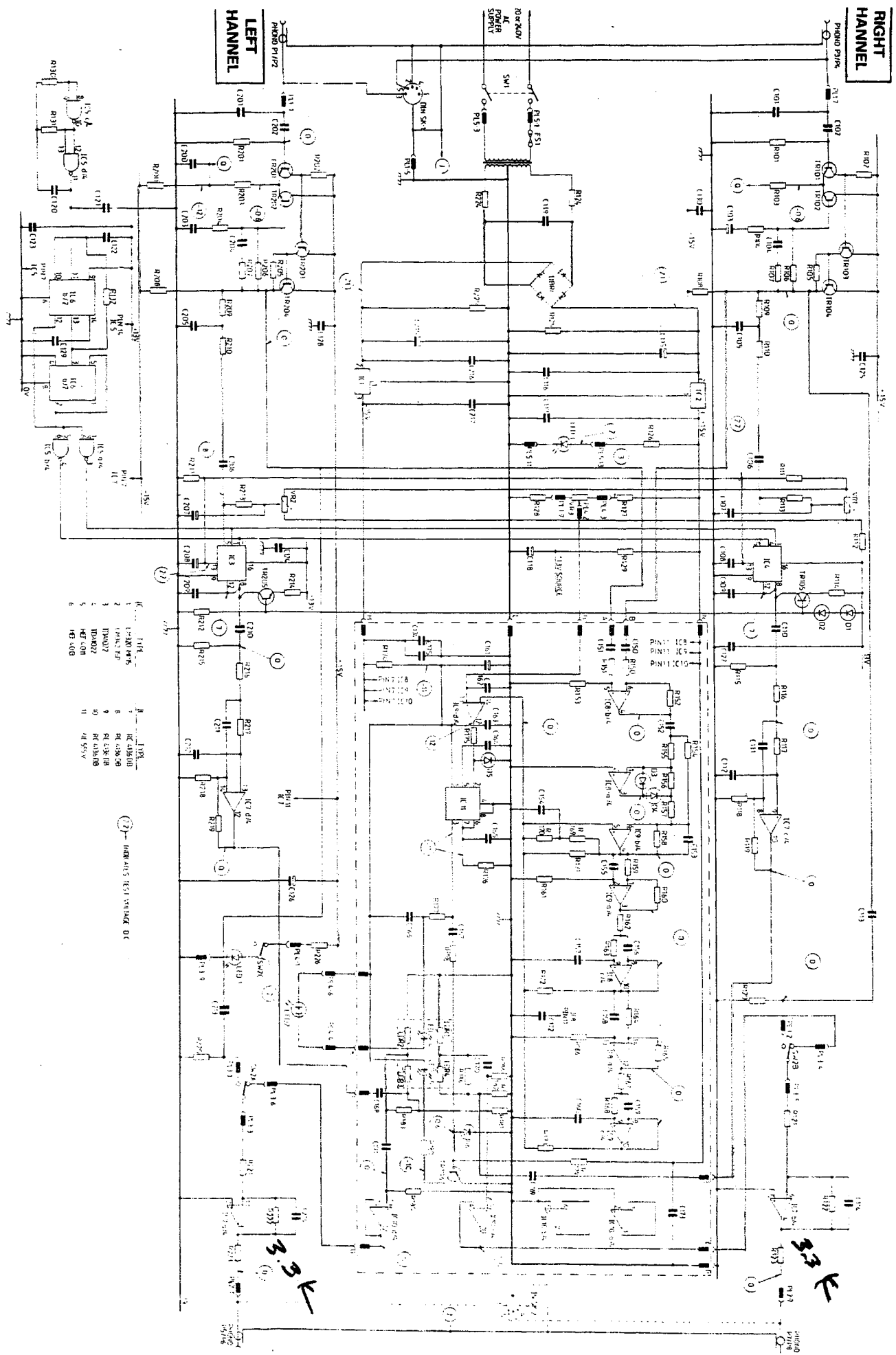

Diagram 9 Removal of 'Rokut' rivet



- | IC | TYPE |
|----|-------|
| 1 | 12AX7 |
| 2 | 6X4 |
| 3 | 6AV6 |
| 4 | 6AV6 |
| 5 | 6AV6 |
| 6 | 6AV6 |
| 7 | 6AV6 |
| 8 | 6AV6 |
| 9 | 6AV6 |
| 10 | 6AV6 |
| 11 | 6AV6 |
| 12 | 6AV6 |

(Z) - IDENTICAL TO CHANNEL DC

Diagram 10 Circuit diagram

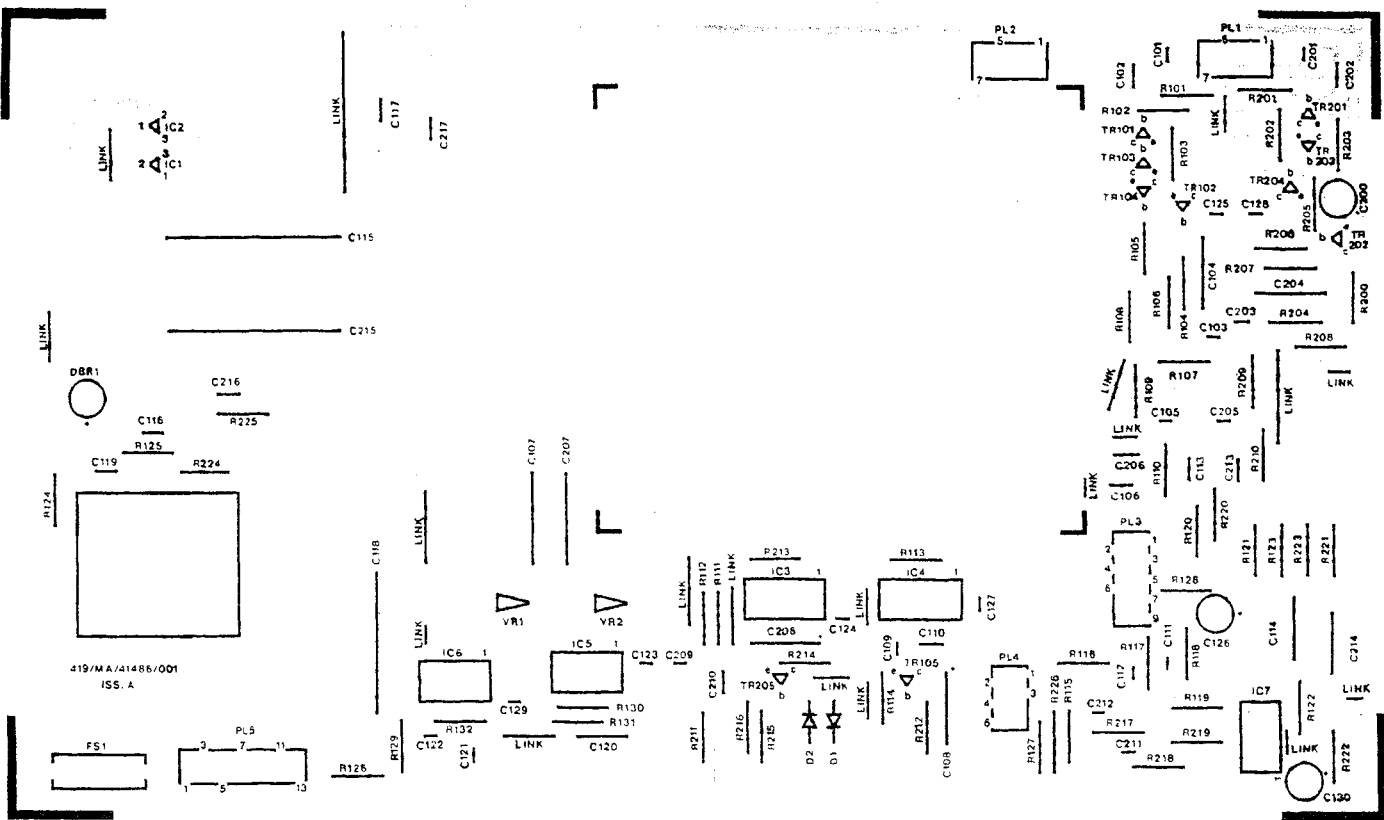

Diagram 11 Main P.C.B. layout

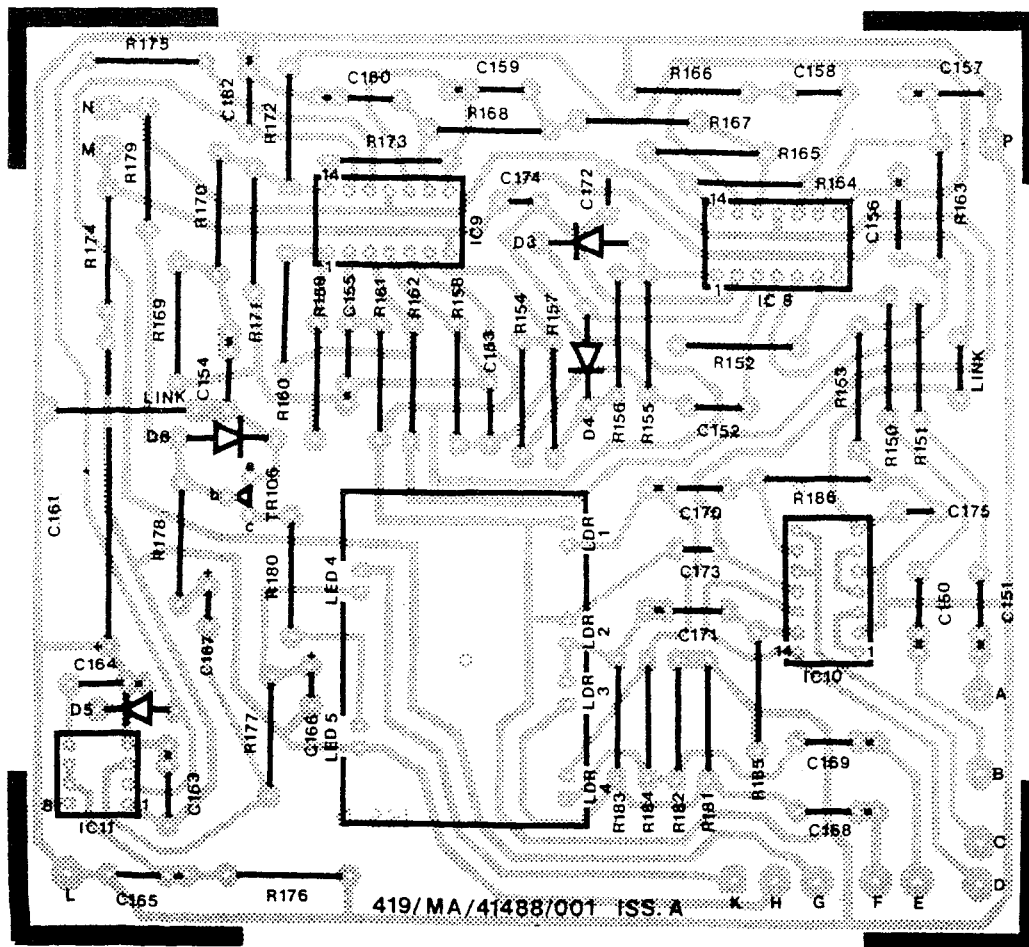

Diagram 12 Sub P.C.B. layout

Spare Parts (continued)

Ref. No.	Garrard Part Number	Description			
R128		47R			
R129		100R			
R130		22K			
R131		8K2			
R132		3K9			
R150		22K			
R151		22K			
R152		100K			
R153		100K			
R154		36K			
R155		22K			
R156		22K			
R157		18K			
R158		33K			
R159		10K			
R160		10K			
R161		10K			
R162		5K6			
R163		5K6			
R164		10K			
R165		10K			
R166		10K			
R167		5K6			
R168		5K6			
R169		15K			
R170		15K			
R171		10K			
R172		10K			
R173		8K2			
R174		470R			
R175		10K			
R176		27K			
R177		150R			
R178		2K2			
R179		18K			
R180		150R			
R181		330K			
R182		330K			
R183		180K			
R184		180K			
R185		470K			
R186		470K			
R200		10K			
R201		47K			
R202		10K			
R203		100K			
R204		680R			
R205		2K2			
R206		360K	1/3 watt	± 2%	
R207		39K	1/3 watt	± 2%	
R208		3K3			
R209		3K3			
R210		3K3			
R211		2K2			
R212		22K			
R213		56K			
R214		820R			
R215		1M			
R216		120K			
R217		120K			
R218		3K3			
R219		3K3			
R220		1M			
R221		39K			
R222		51K	1/3 watt	± 2%	
R223		3K3			
R224		22R			
R225		10K			
R226		1K5			
		Potentiometers			
VR1		10K	1/5 watt	± 20%	Preset
VR2		10K	1/5 watt	± 20%	Preset
VR3		10K	1/2 watt	± 20%	Anti-log

Ref. No.	Garrard Part Number	Description			
Capacitors					
C101		10p	500V	± 10%	Ceramic
C102	435/4/91010/125	470n	100V	± 10%	Polycarbonate
C103	402/4/56425/223	22μ	25V	± 20%	Tantalum
C104		8n2	63V	± 2½%	Polystyrene
C105		470p	500V	± 20%	Ceramic
C106	435/4/91010/023	220n	100V	± 5%	Polycarbonate
C107		1μ	63V	+75% -10%	Electrolytic
C108		1μ	63V	+75% -10%	Electrolytic
C109		680p	500V	±20%	Ceramic
C110		100n	100V	±5%	Polycarbonate
C111		68p	500V	±10%	Ceramic
C112		22p	500V	±10%	Ceramic
C113	435/4/91010/024	330n	100V	±5%	Polycarbonate
C114		1n5	63V	±2½%	Polystyrene
C115	402/4/56423/043	2200μ	40V	+50% -10%	Electrolytic
C116	435/4/91010/125	470n	100V	±10%	Polycarbonate
C117	435/4/91010/021	100n	100V	±5%	Polycarbonate
C118		470μ	25V	+50% -10%	Electrolytic
C119	435/4/91010/125	470n	100V	±10%	Polycarbonate
C120		220p	63V	± 1%	Polystyrene
C121		22p	500V	± 10%	Ceramic
C122		100p	500V	± 10%	Ceramic
C123		10n	500V	+40% -20%	Ceramic
C124		10n	500V	+40% -20%	Ceramic
C125		10n	500V	+40% -20%	Ceramic
C126		220μ	25V	+50% -10%	Electrolytic
C127		10n	500V	+40% -20%	Ceramic
C128		10n	500V	+40% -20%	Ceramic
C129		10n	500V	+40% -20%	Ceramic
C130		220μ	25V	+50% -10%	Electrolytic
C150	437/4/30727/011	10n	250V	± 5%	Polycarbonate
C151	437/4/30727/011	10n	250V	± 5%	Polycarbonate
C152	437/4/30727/021	100n	100V	± 5%	Polycarbonate
C153	435/4/91010/103	2n2	250V	± 10%	Polycarbonate
C154	437/4/30727/025	0.47μ	100V	± 5%	Polycarbonate
C155	435/4/91010/112	15n	250V	± 10%	Polycarbonate
C156	437/4/30727/015	47n	250V	± 5%	Polycarbonate
C157	437/4/30727/013	22n	250V	± 5%	Polycarbonate
C158	435/4/91010/112	15n	250V	± 10%	Polycarbonate
C159	437/4/30727/015	47n	250V	± 5%	Polycarbonate
C160	437/4/30727/013	22n	250V	± 5%	Polycarbonate
C161		470μ	25V	+50% -10%	Electrolytic
C162	437/4/30727/011	10n	250V	± 5%	Polycarbonate
C163	437/4/30727/011	10n	250V	± 5%	Polycarbonate
C164	437/4/30727/011	10n	250V	± 5%	Polycarbonate
C165	437/4/30727/021	100n	100V	± 5%	Polycarbonate
C166	402/4/56425/216	6μ8	25V	± 20%	Tantalum
C167	402/4/56425/261	1μ	35V	± 20%	Tantalum
C168	437/4/30727/025	0.47μ	100V	± 5%	Polycarbonate
C169	437/4/30727/025	0.47μ	100V	± 5%	Polycarbonate
C170	437/4/30727/021	100n	100V	± 5%	Polycarbonate
C171	437/4/30727/021	100n	100V	± 5%	Polycarbonate
C172		10n	500V	+40% -20%	Ceramic
C173		10n	500V	+40% -20%	Ceramic
C174		10n	500V	+40% -20%	Ceramic
C175		10n	500V	+40% -20%	Ceramic
C200		220μ	25V	+50% -10%	Electrolytic
C201		10p	500V	±10%	Ceramic
C202	435/4/91010/125	470n	100V	±10%	Polycarbonate
C203	402/4/56425/223	22μ	25V	±10%	Tantalum
C204		8n2	63V	±2½%	Polystyrene
C205		470p	500V	±20%	Ceramic
C206	435/4/91010/023	220n	100V	± 5%	Polycarbonate
C207		1μ	63V	+75% -10%	Electrolytic
C208		1μ	63V	+75% -10%	Electrolytic
C209		680p	500V	± 20%	Ceramic
C210	435/4/91010/021	100n	100V	± 5%	Polycarbonate
C211		68p	500V	± 10%	Ceramic
C212		22p	500V	± 10%	Ceramic
C213	435/4/91010/024	330n	100V	± 5%	Polycarbonate
C214		1n5	63V	± 2½%	Polystyrene
C215	402/4/56423/043	2200μ	40V	+50% -10%	Electrolytic
C216	435/4/91010/125	470n	100V	± 10%	Polycarbonate
C217	435/4/91010/021	100n	100V	± 5%	Polycarbonate

Ref. No.	Garrard Part No.	Description
----------	------------------	-------------

Transistors

TR101		BC413
TR102		BC413
TR103		BC214C
TR104		BC184C
TR105		BC214C
TR106		BC214C
TR201		BC413
TR202		BC413
TR203		BC214C
TR204		BC184C
TR205		BC214C

Diodes

D1		1N914
D2		1N914
D3		1N914
D4		1N914
D5		1N914
D6		1N914

Integrated Circuits

IC1	446/4/02981/001	LM320 MP15
IC2	446/4/02978/001	LM342 15P
IC3	449/4/01396/001	TDA 1022
IC4	449/4/01396/001	TDA 1022
IC5	449/4/01397/001	HEF 4011
IC6	449/4/01394/001	HEF 4013
IC7	446/4/02983/001	RC 4136 DB
IC8	446/4/02983/001	RC 4136 DB
IC9	446/4/02983/001	RC 4136 DB
IC10	446/4/02983/001	RC 4136 DB
IC11	446/4/02985/001	NE 555V

Various

DBR1	415/4/04366/001	Bridge Rectifier	100mA	40V
FS1	518/4/90640/007	Fuse (20mm)	100mA	Timelag
LDR1-4	520/4/95009/001	Resistor - Light Dependent		(4)
LED4,5	520/4/95008/001	L.E.D.		(2)
PL1	508/4/22404/002	'Thru-line' 4-way P.C.B. plug		
PL2	508/4/22404/002	'Thru-line' 4-way P.C.B. plug		
PL3	508/4/22404/009	'Thru-line' 9-way P.C.B. plug		
PL4	508/4/22404/007	'Thru-line' 6-way P.C.B. plug		
PL5	508/4/22404/001	'Thru-line' 7-way P.C.B. plug		

Dismantling

Reference numbers in brackets are those used on diagrams 2-6.

To remove the chassis from the cabinet

1. Turn the power switch to 'Off' and disconnect the module from its power supply. Unplug any input, output or signal ground leads from their sockets at the back of the module, noting locations for reassembly.
2. Turn the module upside down, place it on a protective surface and remove four screws (44) from the isolator feet (42), being careful not to lose the associated bushes (43). Remove both remaining screws (41) and washers (40) from the bottom of the cabinet and turn the module the right way up again.
3. The chassis can now be withdrawn from the front of the cabinet, taking care not to damage the top of the transformer (36) in the process. Lift the front of the chassis to ease its rear flange out through the cabinet. Do not use force and take care to avoid tension on the power supply lead as the chassis emerges.

When refitting the chassis, ease the transformer and wiring looms under the front edge of the cabinet.

To remove the printed circuit board (P.C.B.) (27)

CAUTION: When handling the P.C.B., take care not to bend it.

1. Dismantle the chassis from the cabinet as already described.
2. Unplug all connectors from the P.C.B., noting their locations for reassembly.
3. Eight 'Rokut' rivets (26) or five rivets and three nuts - secure the P.C.B. to the chassis. Remove the rivets, by driving their central spigots upwards through the P.C.B. until they can be withdrawn from the top of the board. (A small screwdriver is a convenient tool.) Remove any remaining fixing nuts and washers from the bottom of the chassis. Finally, press the rivets up through the chassis to release the P.C.B.

Note: When refitting the P.C.B. check that all spacer washers (38) are in place. To refit the rivets, press them back down through the P.C.B. and chassis, then push the central spigots down until they are flush with the top of the domed rivet head.

To remove the power supply lead (2)

1. Dismantle the chassis from the cabinet as already described.
2. Unsolder the lead from the power switch terminals (30).
3. The lead is secured to the back of the chassis by means of a moulded 'Heyco' bush (1). To release the lead, compress the

top and bottom of the bush inside the chassis, using a pair of pliers, while pushing the bush out through the back of the chassis.

To remove the fascia panel (28)

1. Pull off the small power switch and suppressor control knobs (23) and the large suppressor sensitivity knob (24).
2. Take the nuts off the three control spindles and remove the fascia panel, taking care to retain the spacers (29) fitted between the panel and the chassis. Do not scratch the aluminium panel.

To dismantle the fader assembly (13)

1. Remove the chassis from the cabinet.
2. Take out the screw (15) securing the two black housings.
3. Unwind the black tape or release the black light-proof band from around the housings and lift off the top housing. The components are all now accessible.

It is most important for correct operation that the backs of the light dependent resistors and L.E.D.'s are all seated flat against their respective faces in the cavities in the bottom housing.

To remove an indicator lamp (L.E.D.) (22 or 25)

1. Dismantle the chassis from the cabinet.
2. Lever the collar off the mounting bush (20) - away from the chassis flange - and withdraw the lamp.
3. Carefully cut away both heat-shrink insulated sleeves and unsolder the lamp connections, noting which lead is nearer to the flat on the L.E.D. mounting flange.
4. When reassembling, insulate both connections again using replacement sleeves or P.V.C. tape. Press the lamp fully into the mounting bush, before refitting the collar.
To replace a mounting bush it will be necessary to take off the fascia panel, remove the collar and lamp and press the bush out through the front of the chassis flange.

To remove power supply switch, sensitivity control or suppressor switch

1. Dismantle the chassis from the cabinet and take off the fascia panel (28) - see previous paragraphs.
2. Unsolder the connecting leads, after noting their positions on the control terminals, and withdraw the control.

When reassembling note that all controls have spigots which must locate in corresponding holes in the chassis. Refit the three spacing washers behind the fascia panel.

Test Procedures

Instruments required

- (a) Dual channel oscilloscope, with timebase accuracy better than 5% (preferably better than 3%).
- (b) Toneburst generator, capable of a single cycle toneburst - 1.6kHz fundamental, 10Hz repetition rate, or Pulse generator, capable of generating a doublet pulse of 600µs duration, 10Hz repetition rate.
- (c) Sinewave oscillator, producing 20Hz, 1kHz and 20kHz.
- (d) DC voltmeter, to measure 25V ± 2V.
- (e) AC millivoltmeter, to measure from 9V rms to 20mV rms, 20Hz to 20kHz, better than 0.5dB.
- (f) AC microvoltmeter, to measure 50µV rms to 200µV rms, bandwidth 20Hz to 20kHz.
- (g) Counter/timer, to measure up to 100kHz.
- (h) Distortion factor meter, to measure less than 0.01% distortion.
- (i) Low-distortion oscillator, less than 0.01% distortion at 1kHz.

Tests

1. Indicator lamp polarity and operation

Conditions: Connect the MRM to a power supply of appropriate AC voltage - as shown on its back panel. Short circuit both input channels. Switch the power on and suppressor in.

Check: Power and suppressor indicators are operative.

2. Transformer and loading

Instrument: DC voltmeter.
Conditions: As for Test 1.
Check: DC voltage on both main power supply capacitors (C115, C215) to be 21V ± 3V.

3. Channel balance and output

Instruments: Sinewave oscillator, oscilloscope, AC millivoltmeter.
Conditions: Switch suppressor out. Apply 1kHz sinewave signal to input terminals in turn.
Check: Channel balance must be better than ± 1dB. Maximum output before visible clipping to be greater than 7V rms.

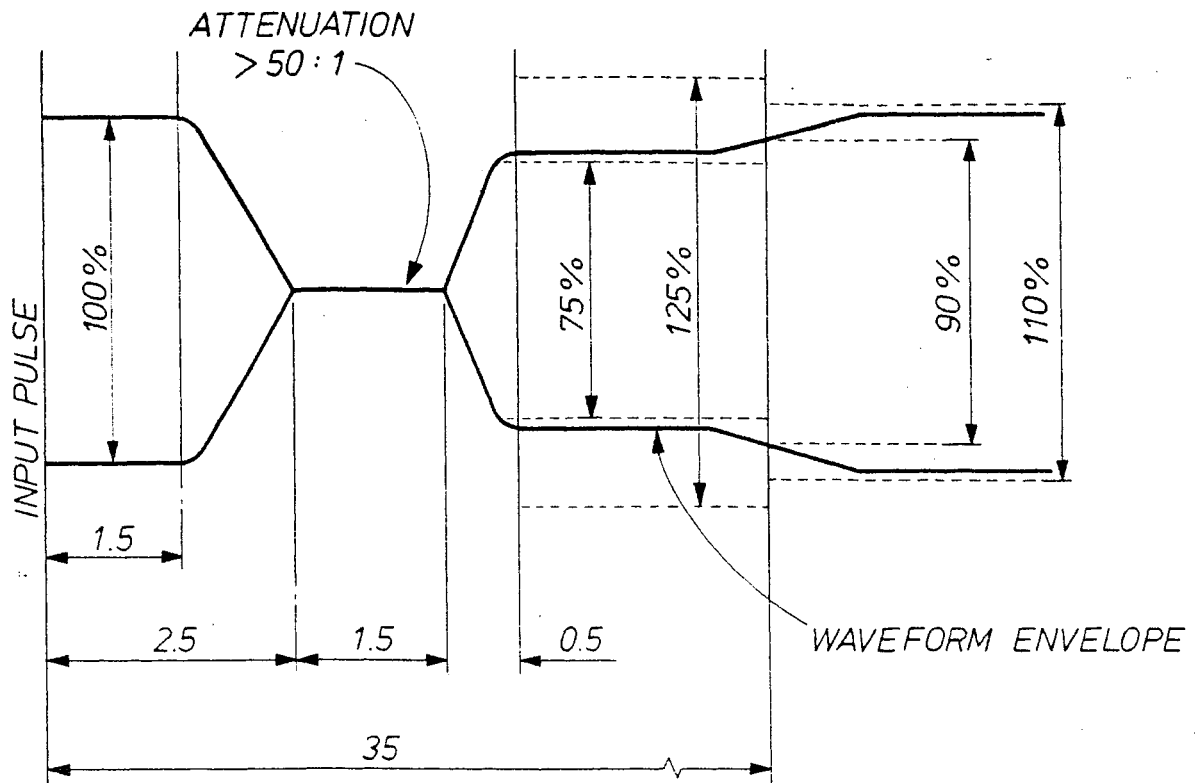

Diagram 14 Oscilloscope waveform - test 10

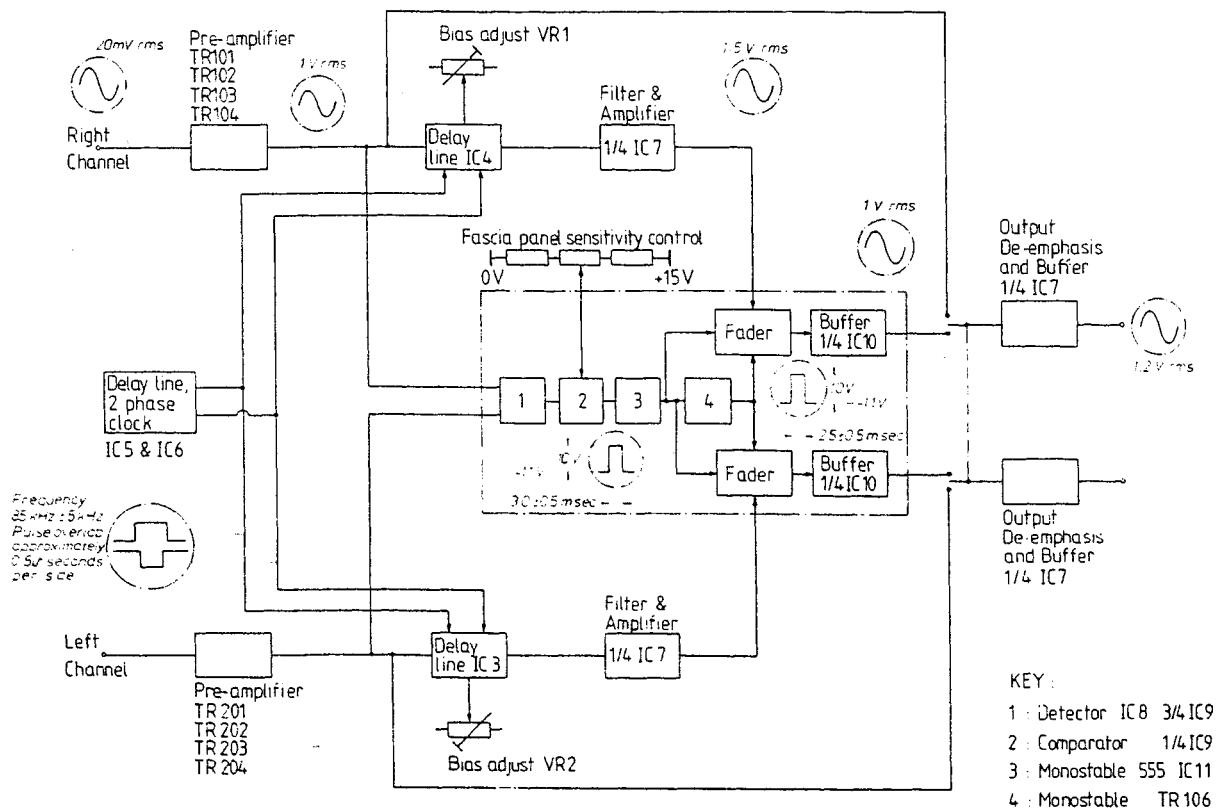

Diagram 13 Block diagram

4. RIAA frequency response

Instruments: Sinewave oscillator, AC millivoltmeter.

Conditions: Switch suppressor out.

Check: Gain at 20Hz to be $+16.4\text{dB} \pm 1.5\text{dB}$.
Gain at 20kHz to be $-19.6\text{dB} \pm 1.5\text{dB}$.
Both with reference to gain at 1kHz.
Test both channels.

5. Maximum delay line dynamic range and gain balance

Instruments: Sinewave oscillator, oscilloscope, AC millivoltmeter.

Conditions: Switch suppressor in. Apply 1kHz sinewave signal to input terminals in turn. Adjust preset potentiometers (VR1, VR2) for minimum visible clipping at 2V rms output. This will have a limited effect on the nominal 7V DC test voltage shown at the delay line output (IC4, pins 8 and 12).

Check: Distortion at 2V rms at 1kHz must be less than 1%. Channel balance at 0.3V rms output must be $\pm 2\text{dB}$.

Switch suppressor out and recheck.

Conditions: Switch suppressor in. Apply 50mV rms at 20kHz sinewave to input terminals in turn. Adjust preset potentiometers (VR1, VR2) for minimum distortion and 'fuzz' on output signal.

6. Detector operation (part of)

Conditions: Switch suppressor in, set suppressor sensitivity control to maximum.

Check: With no input, the suppressor activity indicator must not light.

7. Delay length

Instrument: Counter/timer.

Conditions: Switch suppressor in.

Check: Clock frequency must be 80kHz to 92kHz.

8. Detector operation (part of)

Instrument: Toneburst or pulse generator.

Conditions: Switch suppressor in. Apply a single cycle toneburst or doublet pulse at 10Hz repetition rate, 1.6kHz fundamental or 600 μs duration, of 5mV peak-to-peak amplitude, to one input channel. Short-circuit the other input. Set suppressor sensitivity control to maximum.

Check: The suppressor indicator must flash.
Reverse channels and recheck.

9. Blanking operation (part of)

Instrument: Toneburst or pulse generator.

Conditions: As for Test 8, but with amplitude increased to 100mV peak-to-peak.

Check: The attenuation of the toneburst, between suppressor switched out and in must be greater than 50:1.

10. Blanking operation (part of)

Instruments: Toneburst or pulse generator, oscillator and oscilloscope.

Conditions: Switch suppressor in. Apply a signal source as for Test 8, but with amplitude increased to 100mV peak-to-peak, to one channel. Apply a 1kHz sinewave signal, 5mV rms amplitude to the other channel. Trigger the oscilloscope with the pulse input and observe the sinewave output.

Check: From the start of the input ('scope trigger) pulse, the waveform must reach $100\% \pm 25\%$ of the prior level within 5ms. It must stay at $100\% \pm 25\%$ until it reaches $100\% \pm 10\%$ of the final value after a total of 35ms.
Reverse channel inputs and recheck.
See oscilloscope waveform, diagram 14.

11. Delay line gain

Instruments: Sinewave oscillator, AC millivoltmeter.

Conditions: Switch suppressor in. Apply 1kHz sinewave to both input channels to obtain 200mV rms nominal output.

Check: Channel balance to be better than 2dB.
Difference in output between suppressor switched out or in must be within 2dB on both channels.

12. Delay and processing frequency response

Instruments: Sinewave oscillator, AC millivoltmeter.

Conditions: Switch suppressor in. Apply a 1kHz sinewave input to both channels to obtain a 200mV rms nominal output.

Check: Gain at 20Hz must be $16.4\text{dB} \pm 1.5\text{dB}$.
Gain at 20kHz must be $-19.6\text{dB} \pm 1.5\text{dB}$ with reference to arbitrary 0dB at 1kHz at approximately 200mV rms output.
Test both channels.

13. Preamplifier ('straight through') noise

Instrument: AC microvoltmeter.

Conditions: Switch suppressor out. Short-circuit both input channels.

Check: Output hum and noise, 20Hz to 20kHz, must be less than 80 μV rms.

15. Preamplifier output

Instruments: Sinewave oscillator, AC millivoltmeter.

Conditions: Switch suppressor out. Apply 1kHz sinewave input to both channels.

Check: Output before visible clipping must be greater than 7V rms.

16. Preamplifier distortion

Instruments: Sinewave oscillator, distortion factor meter, AC millivoltmeter.

Conditions: Switch suppressor out. Apply a 1kHz sinewave input to both channels, to give approximately 200mV rms output.

Check: Distortion must be less than 0.01%.

17. Delay line distortion

Instruments: Sinewave oscillator, distortion factor meter, AC millivoltmeter.

Conditions: Switch suppressor in. Apply a 1kHz sinewave input to both channels, to give approximately 200mV rms output.

Check: Distortion must be less than 0.10%.

18. Delay line noise

Instrument: AC microvoltmeter.

Conditions: Switch suppressor in. Short circuit both input channels.

Check: Output hum and noise, 20Hz - 20kHz, must be less than 200 μV rms.

Printed by Borough Press (Wiltshire) Limited